

| REVISION HISTORY | | | |
|------------------|-------------|------|----------|
| REV | DESCRIPTION | DATE | APPROVED |

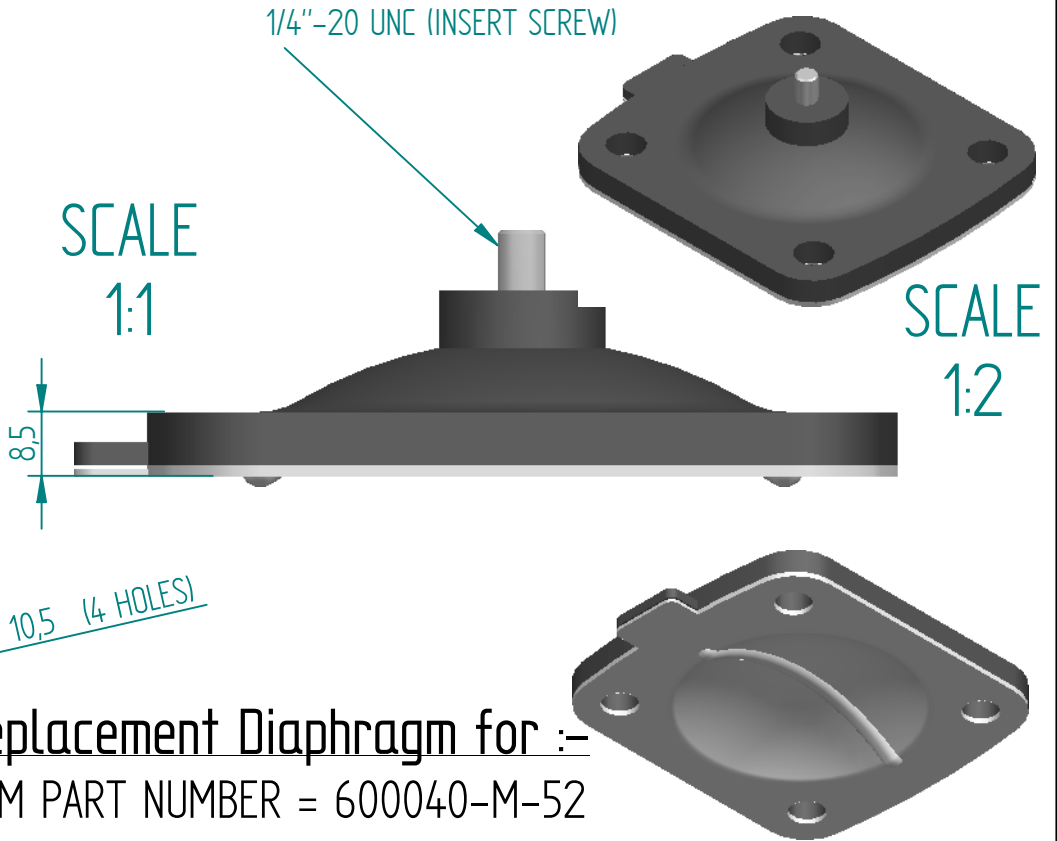

Replacement Diaphragm for :-
 OEM PART NUMBER = 600040-M-52
 USED ON 1.5" (DN40) Diaphragm Valve

| | | |
|---------|-----------|----------|
| | NAME | DATE |
| DRAWN | M.MC KEON | 08/29/14 |
| CHECKED | | |



Material -
EPDM BACKING
PTFE - DIAPHRAGM

TITLE
DD15-GTFM

Complies with CFR 177.2600
 and Conforms to
 USP Class VI Biological Reactivity
 Tests Section #87 and #88

| | | |
|-----------|------------------------------|----------|
| SIZE A | FOOT PRINT DIMENSIONS | REV B |
|-----------|------------------------------|----------|

| | | | |
|--------------------------|--------------|----------|--------------|
| FILE NAME: DD15-GTFM.dft | SCALE: 1 : 1 | ECO:0605 | SHEET 1 OF 1 |
|--------------------------|--------------|----------|--------------|

Disclaimer - Diaphragm Direct® does not manufacture, represent, nor sell OEM valves or diaphragms manufactured by any other company. Diaphragm Direct® brand diaphragms are not sponsored by any other manufacturers. Any name, model, part number, brand, image, material or referral is for descriptive purposes only. Diaphragm Direct® brand replacement diaphragms are guaranteed to fit OEM equipment and meet or exceed OEM specifications. Diaphragm Direct® brand replacement diaphragms are covered by the standard Diaphragm Direct® limited product warranty.